



www.AKCP.com

ropeWater Sensor



Table of contents

1. Introduction
2. Features
3. Configuring the ropeWater sensor
4. Configuring the ropeWater sensor on a sensorProbe unit
5. Configuring the ropeWater sensor on a securityProbe or a securityProbe 5E unit
6. Detection of Acid
7. Mounting the ropeWater sensor

Introduction

Water can enter a building in many different ways and, in some cases, remain undetected. This can cause damage and problems to sensitive electronic equipment. Computer and mainframe rooms which have a false floor and ceilings could harbor undetected water, which is only detected after a problem occurs.

The ropeWater sensor is capable of detecting the presence of or non-presence of water. It contains a microprocessor controlled capacitance measuring circuit which is far more precise than commercially available standard water detectors which measure the resistance of water.

The detector provides feedback to the web based interface which will indicate the presence/absence of water with a Normal/Alert, or Critical indication. The unit will retain any error condition until it is read via a *snmpget*. Therefore, if it encounters a critical condition at any time, it will report that condition before it returns to a normal state.

The value of the status for the SNMP OID for the ropeWater sensor can be Normal, No Status, Critical or Sensor Error.

ropeWater sensor OID:

For a switch type sensor on RJ45#1 the OID for the status is **.1.3.6.1.4.1.3854.1.2.2.1.18.1.3.0**

Features:

- On/Off alarm signal of Water detected
- Accurate, cost effective Water detecting system
- Rope portion of the sensor is submersible
- Sensor type - open/closed contact switch
- Power source: powered by the unit. No additional power needed.
- Power Consumption: Typical 125 mWatt, 25 mA
- The unit auto detects the presence of the ropeWater sensor
- Up to 2 ropeWater sensors per unit sensorProbe2.
- Up to 8 ropeWater sensors per unit sensorProbe8.
- Hundreds of ropeWater sensors per securityProbe 5E and E-sensor8 E-modules
- Full Autosense including disconnect alarm if cut, broken, or disconnected
- Sensing rope cable can be pre-ordered from a 10 foot minimum to any custom run length of up to 165 feet or 50 meters.
- Non-sensing cable comes in a standard 20 foot run length.
- Can be connected to any of the sensorProbe or securityProbe's 8 RJ-45 Intelligent sensor ports or any of the securityProbe 5E's E-sensor8 expansion module ports.
- Can be extended up to 100 feet, or 30 meters using normal CAT5\6 LAN cable from the RJ-45 sensor ports.

- o Measurement range: Wet or Dry (-20 degrees C- +60 degrees C)
- o Comes fully assembled and includes the rope portion that is the water sensing cable, the non-sensing area cable (from the rope to the sensing module) and the main sensing module.

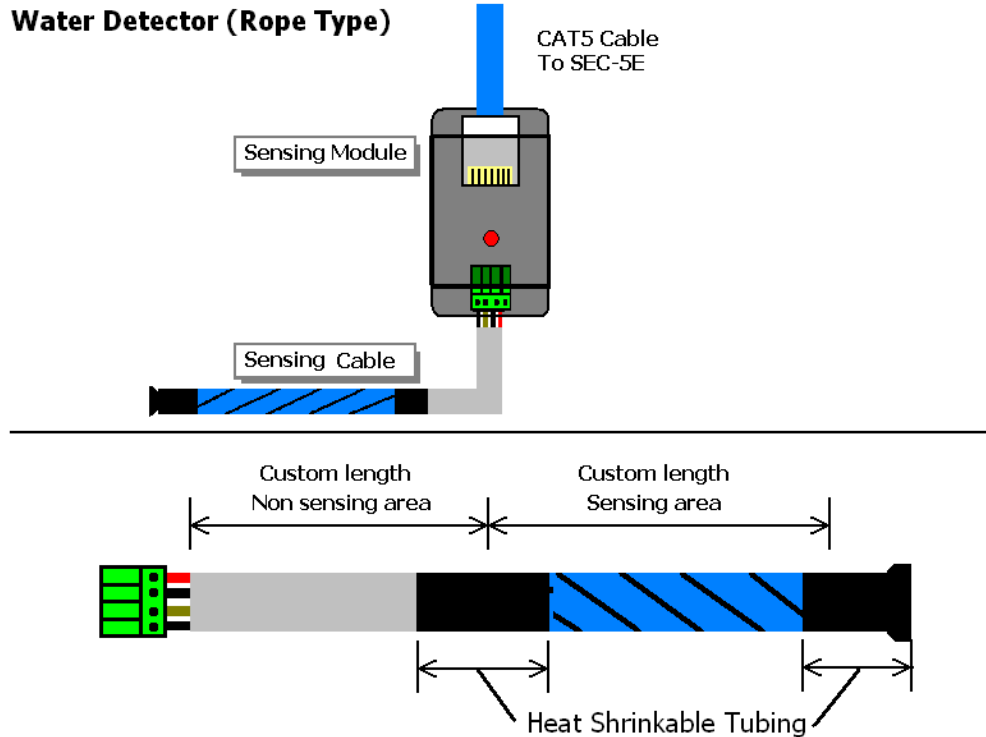

ropeWater sensor product assembly diagram

Configuring the ropeWater sensor

- Plug the sensor into one of the RJ45 ports on the rear panel of the unit or expansion module.
- Now point your browser to the IP address of the unit (default, 192.168.0.100). Next you need to login as the administrator using your administrator password (default is "public"). You will then be taken to the summary page.
- From the summary page you need to select the sensors tab. The layout of the next page will vary depending on your unit so please refer to your unit's manual.
- You should now be able to setup the thresholds for your sensor. The low critical, low warnings, normal, high warnings, high critical values can be set from this page.

Now we will cover the settings that are specific to your sensor.

Status: If the sensor is offline, the status is No Status. If the sensor is online, and there is no water detected, the status is Normal. If water is detected, then the status is Critical. If at any time communications with the ropeWater sensor are lost, the status of the ropeWater sensor is changed to Sensor Error.

Configuring the ropeWater sensor on a sensorProbe unit

The ropeWater sensor shows the “Normal” status in Summery page after connecting the sensor.

Online Status of Sensors				
Port	Type	Description	Reading	Status
1	-	-	-	-
2	-	-	-	-
3	-	-	-	-
4	-	-	-	-
5	Humidity	Humidity5 Description	35 %	Normal
6	Temperature	Temperature5 Description	82 °F	Warning
7	-	-	-	-
8	Water	AKCP ropeWater Sensor Demo	-	Normal

Use the Sensors page and the Water Detector sensor settings in the sensorProbes web interface for configuring the ropeWater sensors settings.

Sensor Settings

Water Sensor Settings

Port: 8

Description: AKCP ropeWater Sensor Demo

Status: Normal

Sensor Online/Offline: Online

Go Online/Offline:

The ropeWater sensor shows the “Critical” status in the Summery page after detecting water.

Online Status of Sensors				
Port	Type	Description	Reading	Status
1	-	-	-	-
2	-	-	-	-
3	-	-	-	-
4	-	-	-	-
5	Humidity	Humidity5 Description	36 %	Normal
6	Temperature	Temperature5 Description	81 °F	Warning
7	-	-	-	-
8	Water	AKCP ropeWater Sensor Demo	-	Critical

Configuring the RopeWater sensor on a securityProbe or a securityProbe 5E unit

The ropeWater sensor shows the “Normal” status in Summary page after connecting the sensor and when water is detected it will show “Critical” in this page and the syslog:

Board Name	Type	Sensor Name	Reading	Status
E.opto16 – 16 opto isolated dry contacts 1	Board	E.opto16 – 16 opto isolated dry contacts 1	-	Normal
E.opto16 – 16 opto isolated dry contacts 2	Board	E.opto16 – 16 opto isolated dry contacts 2	-	Connected
E-sensor8 – 8 intelligent E-Module	Thermocouple	Thermocouple Demo on E-module	74.8 °F	Normal
	Dry contact I/O	Smoke Detector Sensor In Demo Rack	-	Normal
	Humidity	Humidity Port 4 on E-sensor8 – 8 intelligent E-Module	40 %	Low Warning
	Dual Temperature	Temperature Port 4 on E-sensor8 – 8 intelligent E-Module	25.9 °C	Normal
	Relay	Relay Port 6 on E-sensor8 – 8 intelligent E-Module	-	Sensor Error
	Water	ropeWater Sensor	-	Normal
Internal RJ45	Board	Internal RJ45	-	Sensor Error

Time	Message
2000/05/20 14:29:40	Sound Detector status is Normal
2000/05/20 14:29:39	Sound Detector status is Low Warning
2000/05/20 14:29:38	Sound Detector status is Normal
2000/05/20 14:29:38	Sound Detector status is Low Warning
2000/05/20 14:29:37	ropeWater Sensor status is Normal
2000/05/20 14:29:37	ropeWater Sensor status is Critical
2000/05/20 14:29:37	Sound Detector status is Normal
2000/05/20 14:29:37	Sound Detector status is Low Warning
2000/05/20 14:29:35	Sound Detector status is Normal
2000/05/20 14:29:35	Sound Detector status is Low Warning

Use the Sensors page and the Water Detector sensor settings in the sensorProbes web interface for configuring the ropeWater sensors settings.

Sensor Settings

Extended Port1

Extended Port1 | E-sensor8 – 8 intelligent E-Module | E.opto16 – 16 opto isolated dry contacts 2 | E.opto16 – 16 opto isolated dry contacts 1

E-sensor8 – 8 intelligent E-Module

1 Auto Sense Online NC | 2 Auto Sense Online Thermocouple | 3 Auto Sense Online Dry contact I/O | 4 Auto Sense Online Dual Sensors | 5 Auto Sense Online NC | 6 Auto Sense Online Relay | 7 Auto Sense Online NC | 8 Auto Sense Online Water

Sensor Name: AKCP ropeWater Sensor Demo
 Status: Normal
 Sensor Currently: Online

Advanced Mode >>> Save Reset

Detection of Acid

In power monitoring situations where backup battery and UPS are used to ensure a constant power supply there is a risk of battery's leaking harmful battery acid. Use this rope sensor underneath backup battery banks to give advanced warning of battery acid leaks.

Note: This product is designed for short term exposure to battery acid only. Tested with 40% concentrate Sulphuric acid (H₂SO₄)

Mounting the ropeWater sensor

We recommend using any standard plastic U-clip or half U-clip with the adhesive base as shown in these two pictures below. These types of clips can normally be found at your local hardware store.

When installing or handling your new rope sensor, please be sure to handle the rope portion of the sensor with care, avoiding any twisting, excessive bending or putting stress on the rope, as the internal sensing wires are very delicate and can become damaged quite easily.

UC
U-Clip with Adhesive Base

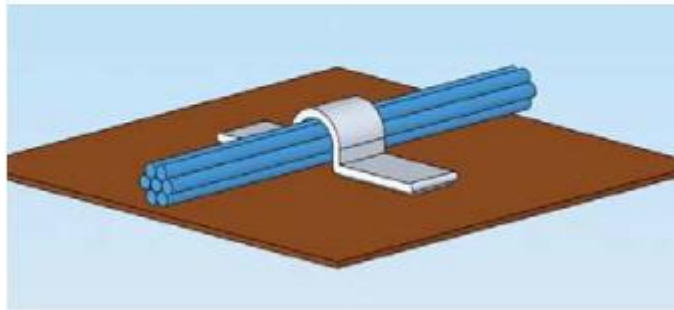

HUC
Half U-Clip with Adhesive Base

