



www.AKCP.com

Cabinet Control Unit (CCU) User Manual



Help Version updated till firmware 404n

Copyright © 2012, AKCess Pro Limited

1) Introduction

What is the CCU?

How to use this manual

2) Package Contents

3) CCU Connections

4) Access Control Components

5) Installation

A) Overview and Installing the Cabinet Lock & Reader

B) Wiring the CCU with card reader and EMI door lock.

C) Pre-wired Accessories

D) Setup & Configuration of the CCU web interface

E) CCU OID's

6) DCU & CCU Frequently Asked Questions

1) Introduction

What is the Cabinet Control Unit, or CCU?

The AKCP Cabinet Control Unit is an unit that connects to the DCU or Door Control Unit and controls access to server cabinets. Each CCU can control access to 1 cabinet. User access rights and schedules are programmable through the AKCess Pro Server software. It is scalable, flexible and fully integrated with our diverse product range. With multiple CCU's it is possible to monitor and control access for hundreds or thousands of cabinets. The connection to the DCU and that Being IP based also means that the CCU is suitable for deployment in a multisite situation where there are several buildings cities, countries or worldwide that require centralized access control management.

Combined with the DCU the CCU can control the access for up to 50 server cabinets. See the separate DCU user manual for more information on the DCU.

Please note that the DCU is a stand-alone base unit and does not need to be connected to any other units to function. However The AKCess Pro Server software plays a key role in the overall operation of the management system and must be used. Please see the separate manuals for setting up the access control or other operational details regarding these products.

AKCP has prided itself on the only company in the world to bring low cost, easy to use complete access control, CCTV security, environmental and power monitoring solutions to market.

How to use this manual

This manual is meant to provide the user with a step by step guide on how to configure and set up their DCU. It utilizes screen shots in an effort to make things simpler for the user to follow. It is split up into sections that form "mini tutorials". These cover the basic set up and common configurations of the unit, and give an introduction to its most useful features.

At the end of the manual there is a FAQ section that provides some further in-depth information regarding specific set ups and answers some commonly asked questions. If you need any further information or help with using your unit then please contact us on support@akcp.com and one of our technical support staff will be only to pleased to help you with any information you require.

2) Package Contents

Your Cabinet Control Unit package contains the following items:-

- 1x Product CD
- 1x 5ft cable
- 1x 12V, 1 Amp power supply

3) CCU Connections

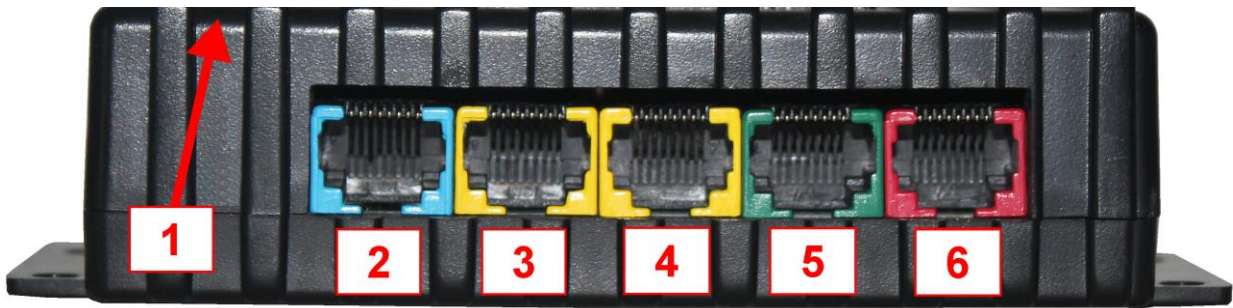

Fig 1. Bottom view of CCU

The CCU has two LED's, several color coded RJ-45 ports and a power input described as follows.

1. CCU Status LED's Located on the front of the CCU

The green LED represents the link to the DCU and will be lit when the unit is successfully connected to the DCU's expansion port. The RED LED represents the power to the unit and will light up when the CCU has the power on.

2. RJ-45 Connection to the CCU or 5ES / 5ESV - Blue

The RJ-45 connection color coded blue is where you will connect the unit to the one of the two expansion IN ports on the DCU(Door Control Unit) or securityProbe 5ES, 5ESV, 5ES-X20 & X60 or 5ESV-X20 & X60 base units or expansion OUT of CCU.

3. RJ45 Sensor Port #1 - Yellow

The RJ-45 connection color coded yellow is where you will connect your AKCP Intelligent Sensors. Note: The sensor must be configured from the AKCess Pro Server software (please see the AKCess Pro Server / Access Control user manual).

4. RJ45 Sensor Port #2 - Yellow

The second RJ-45 connection color coded yellow is where you will connect your AKCP Intelligent Sensors. Note: The sensor must be configured from the AKCess Pro Server software (please see the AKCess Pro Server / Access Control user manual).

5. RJ45 RFID Reader - Green

The RJ-45 connection color coded green is where you will connect your RFID card readers to the CCU.

6. RJ45 Door Lock or Lock Converter Box – Red

The RJ-45 connection color coded red is where you will connect your EMI lock or the Lock Converter Box. The CCU can control a 12V door lock up to 500mA. Please contact support before trying to connect your own EM door lock to the unit.



Fig 2. Left side view of CCU

7. RJ45 Expansion Connection – No Color

The RJ-45 connection located on the left hand side of the unit is where you will connect additional CCU units in your daisy chain when connecting more than a single CCU.



Fig 3. Right side view of CCU

8. Power Input Connection

This is where you will connect the power adapter to the CCU.

4) Access Control Components



A) EM Card Reader = ACR04

Notes: The Electro Magnetic Card Readers are weather proof and designed to be mounted outside or inside of your doors to swipe your EM cards to gain entry and also clock in and out of the Access Control system.



B) EM Cabinet Lock = ACDL02

Notes: The “mini” EM Door Lock is designed to be used with the CCU or Cabinet Controller Unit. See more on this lock in the CCU User Manual.

5) Installation

Important Note: It is highly suggested that a professional locksmith or lock installer be used when installing the locks and other access control equipment.

Fail Secure Type Locks

The Fail Secure type locks would be used in the cabinets or where you would want the cabinets to remain locked if the power is cut for example the Southco cabinet lock.

A) Overview and Installing the Cabinet Lock & Reader

Electromagnetic Type Door Locks or EM Locks (Fail Safe)

Overview

An electromagnetic lock, magnetic lock, or maglock is a locking device that consists of an electromagnet and an armature plate. By attaching the electromagnet to the inside of the cabinet and the armature plate to the cabinet door, a current passing through the electromagnet attracts the armature plate, holding the cabinet door shut.



Unlike an electric strike a magnetic lock has no interconnecting parts and is therefore not suitable for high security applications because it is possible to bypass the lock by disrupting the power supply. Nevertheless, the strength of the AKCess Pro magnetic locks compares well with that of conventional door locks and they cost less than conventional light bulbs to operate.

We highly recommend using a dedicated UPS to provide backup power to the DCU / CCU and to the EM door locks in case of a power interruption.

Technical comparison

Magnetic locks possess a number of advantages over conventional locks and electric strikes. For example, their durability and quick operation can make them valuable in a high-traffic office environment where electronic authentication is necessary.

Advantages

- Easy to install: Magnetic locks are generally easier to install than other locks since there are no interconnecting parts.
- Sturdy: Magnetic locks may also suffer less damage from multiple blows than do conventional locks.

Installation Notes and Concerns

Always keep in mind you have to be very accurate when installing these types of EM cabinet door locks. You must ensure that the metal armature plates are perfectly flat and aligned against the electro magnet. Otherwise the lock will not function correctly or the cabinet doors could be forced open easily.

We suggest the best procedure to follow when installing the locks is to mount the metal armature plate on the cabinet door first, then close the cabinet door and position the EM on the interior of the cabinet to make sure it is perfectly aligned.

Another procedure to follow is before mounting the EM side in place, position it, power it up and make sure it holds.

VERY Important Note: Please keep in mind that it may take up to 5 minutes for the electromagnet to warm up after applying power to it before it will create enough current through the loops of wire (known as a solenoid) to produce the magnetic field which will engage the conductor and hold the armature plate in place.

Then when it is held in place with the magnetic field, mark off on the interior of the cabinet where it should be mounted and include the screw holes. Then, power it off and mount it into place.

We found in our testing that when mounted if the magnet and metal armature plate were not perfectly aligned then the holding power was greatly reduced and we could easily force open the cabinet door. In some instances when installing the EM you may have to insert washers behind the metal lock to push one or the other side out to make it flush with the electro magnet.

ACR04 is pre-wired for the CCU

ACDL02 is pre-wired for the CCU purpose only, it is not strong enough for a door use

B) Wiring the CCU with card reader and EMI door lock

Wiring Sizes and Types

CAT5/6 (Ethernet cable) can be used for all CCU and door accessories. The Door Lock are pre-wired with 3 meters of cable length while the Card Readers with 5 meters of cable length.

CCU Wiring Diagram and Cable Run Lengths

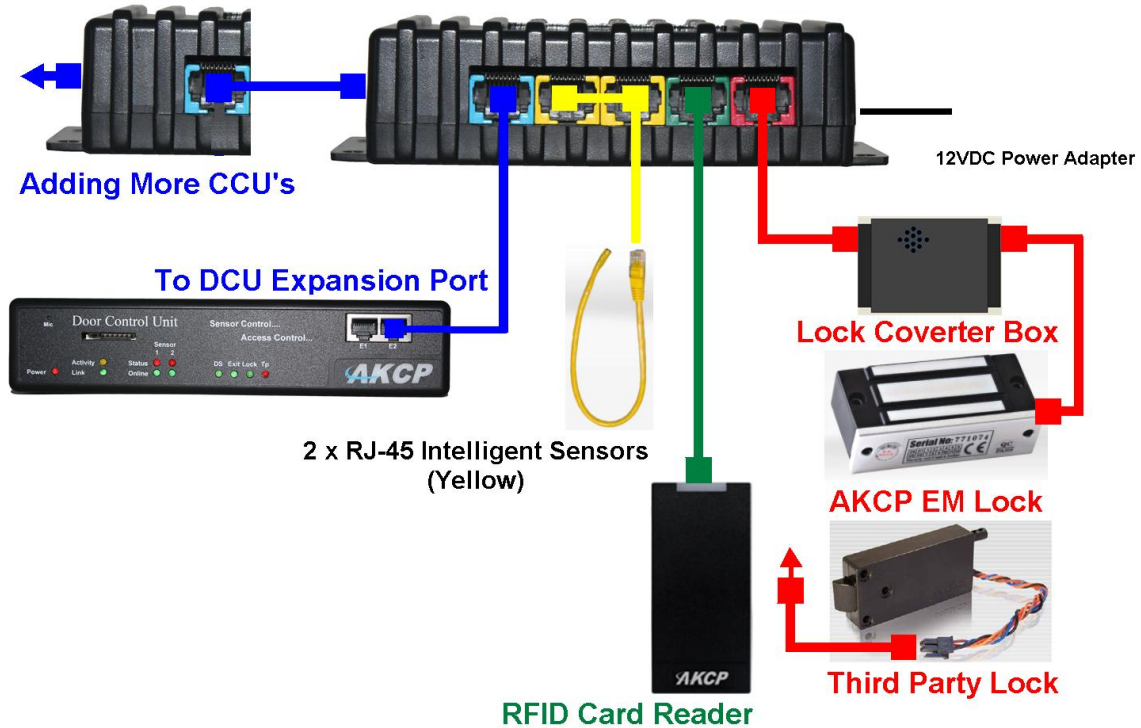

The diagram above shows how to wire up the following:

- A single magnetic cabinet door lock
- 1 RFID card reader
- 1 Lock Converter Box
- Connection to the DCU
- Adding More CCU's
- Connection of 3rd party door lock

The CAT5/6 Cables Should not be extended further than the following;

- 3 meters for the EM door lock
- 5 meters for the RFID card readers
- 300 meters for the cable between the DCU and CCU
- 300 meters between each chained CCU

C) Pre-wired Accessories

ACR04	RFID Reader	
CAT5 line	Reader wire	Description
1	-	-
2	-	-
3	GREEN	Data0
4	Yellow	Buzzer
5	BLUE	LED
6	WHITE	Data1
7	RED	12V
8	BLACK	GND

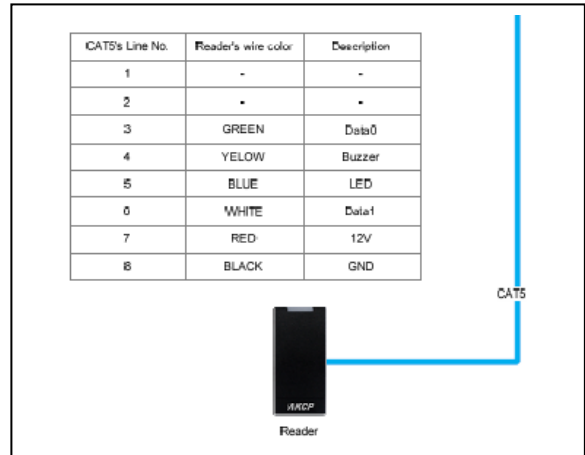

D) Setup & Configuration of the CCU web interface

The CCU is only configurable from the AKCess Pro Server Software

If you have not yet added your DCU that your CCU is connected to into the AKCess Pro Server then this needs to be performed first before you can configure it in the AKCess Pro Server.

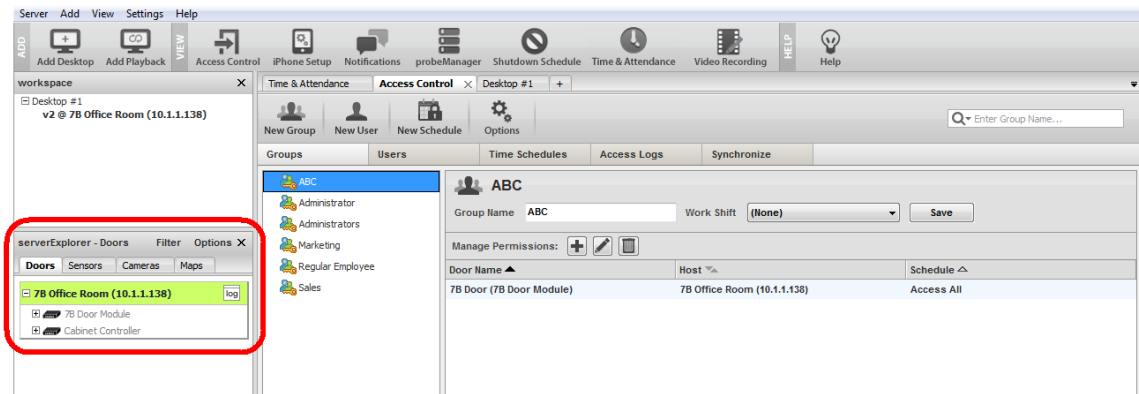

Your CCU, if connected correctly, will be displayed in the serverExplorer panel in the Doors tab as shown in the screen shot above.

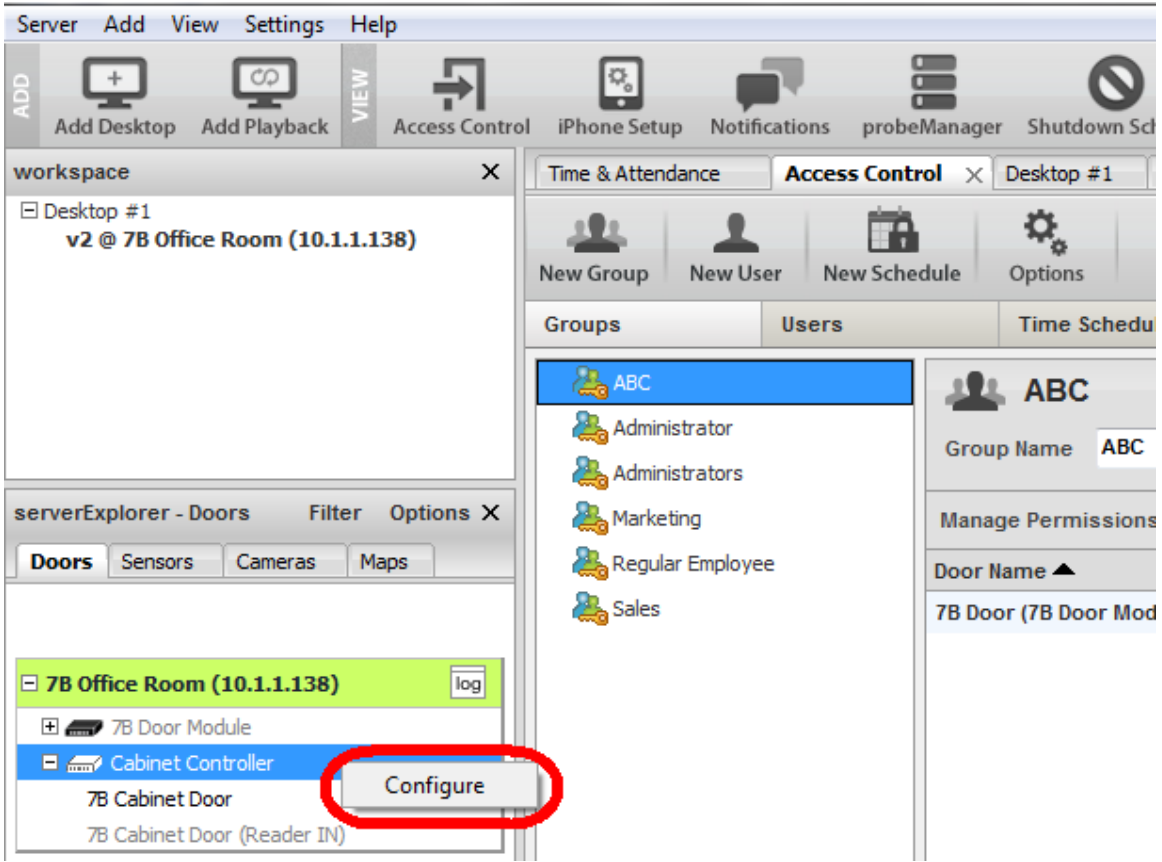

You can now right mouse click on the Cabinet Controller and click the “Configure” button to being setting up your CCU. In the example shown above our CCU is connected to our DCU that has the IP address of 10.1.1.138.

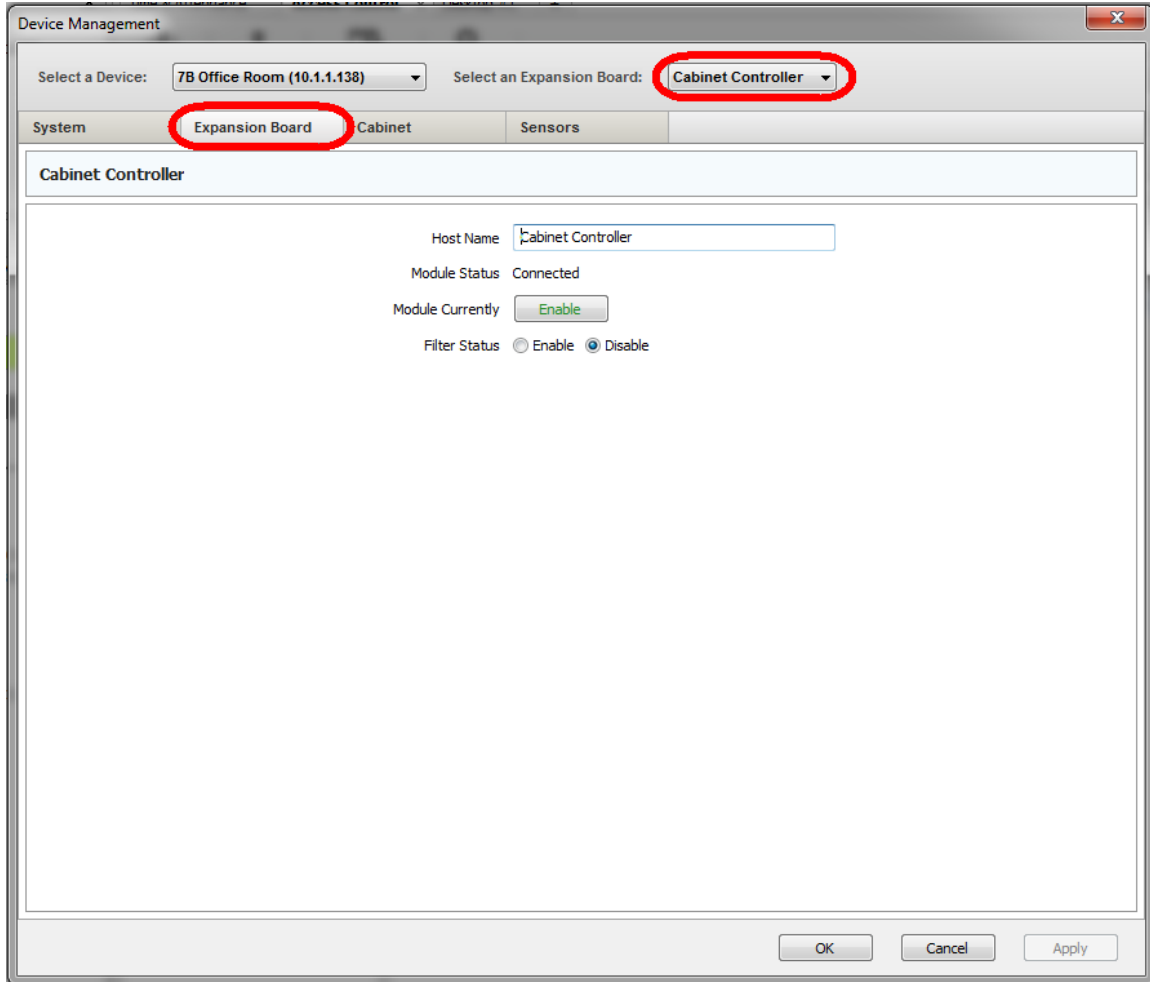

Next as shown in the screen shot above we can rename our CCU, check the status or enable and disable the unit. We can also enable or disable the Filter Status which will filter syslog entries (see SEC 5ES or 5ESV product manual for more information on the syslog filter).

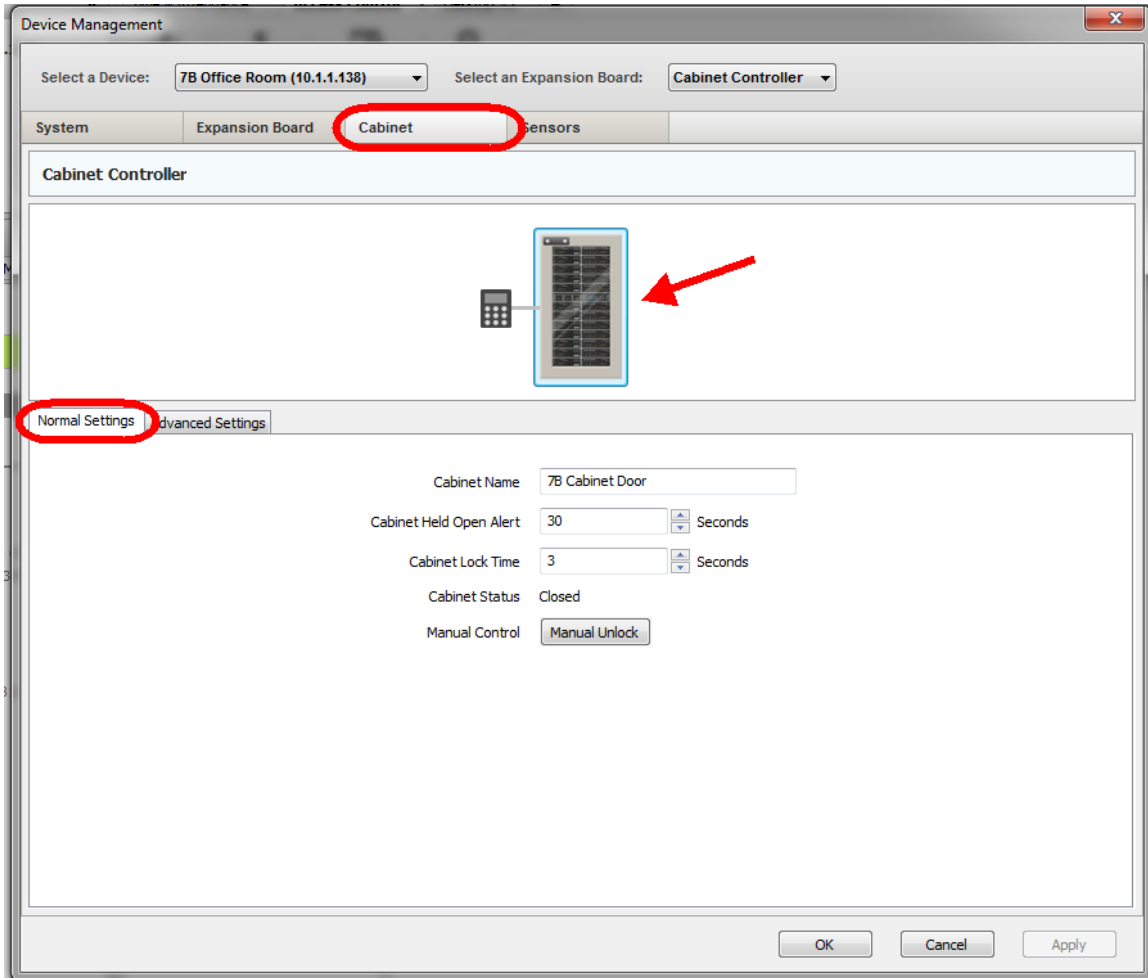

We can now click on the Cabinet tab, click on the cabinet door icon, then set our CCU's Normal Settings such as the cabinet name, our Cabinet Held Open Alert, the Cabinet Lock Time. This page also shows the Status of the cabinet and we Manually unlock or lock the cabinet with the Manual Control button as shown in the screen shot above.

Please Note: The Advanced Settings tab has been removed in the most current version of the AKCess Pro Server software. This feature was previously for setting the dry contact on the lock which is no longer available.

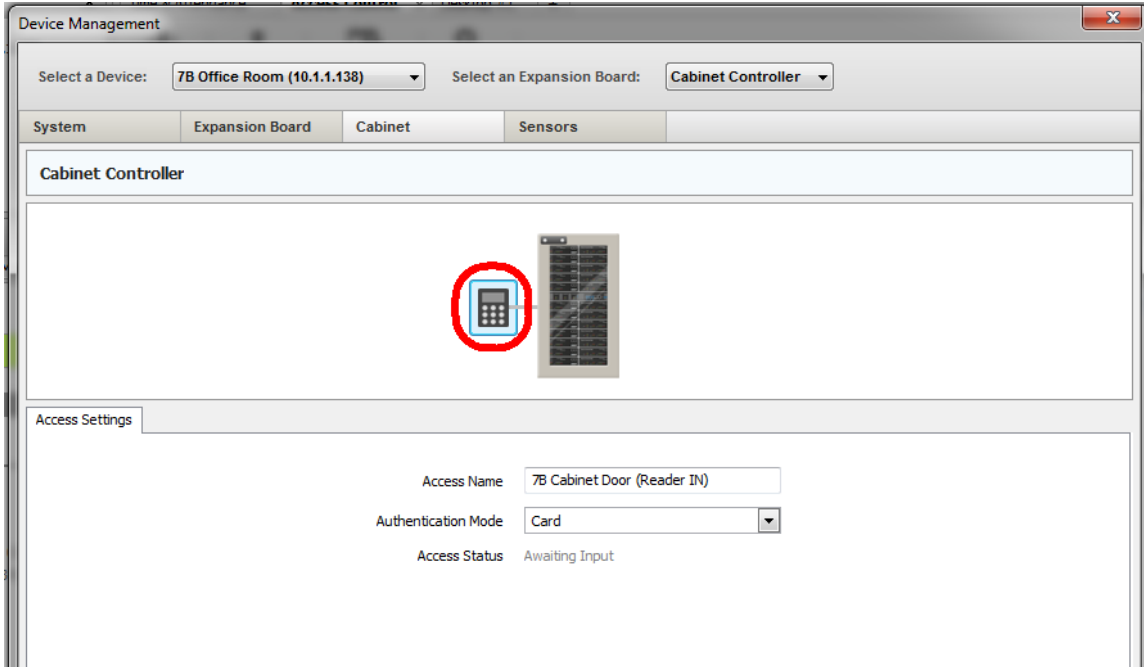

Still viewing the Cabinet tab, we can now setup our card reader by first clicking on the reader icon as shown in the screen shot above.

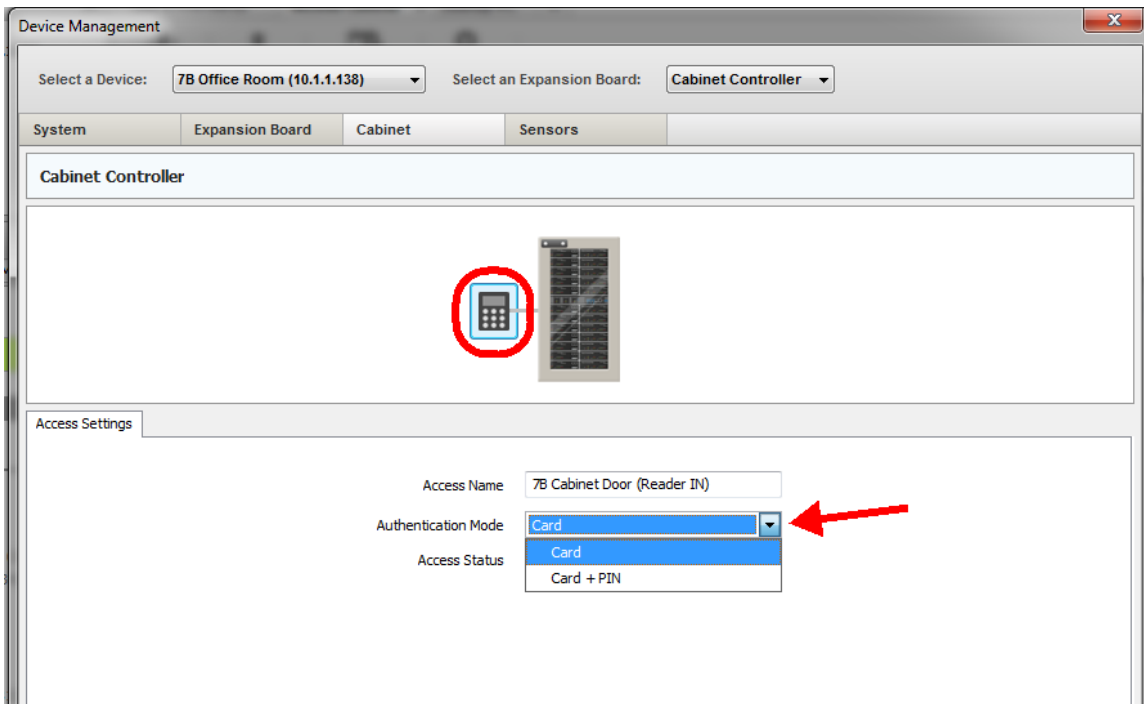

Then renaming our reader and choosing the Authentication Mode from the drop down menu as shown in the screen shot above. Please see the AKCess Pro Server / Access Control product manual for more information on how to setup the users in the system.

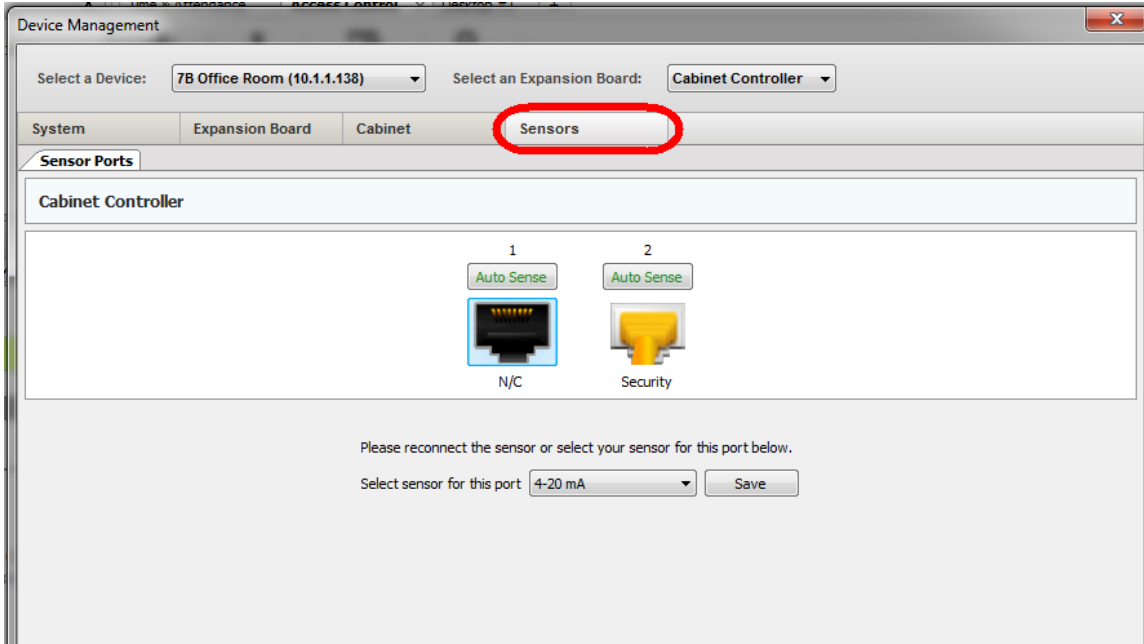

After clicking on the Sensors tab we can setup the sensors connected to our CCU as shown in the screen shot above.

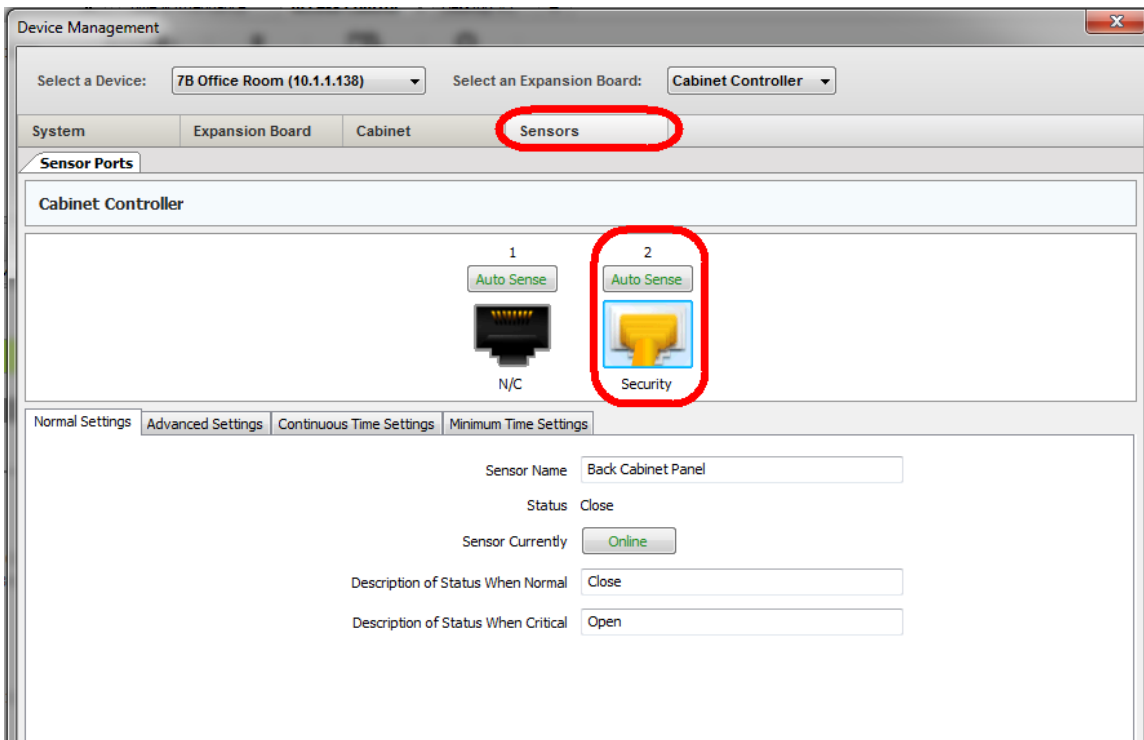

To set each sensor settings you would click on the sensor port icon then set each setting for that sensor as shown in the screen shot above. Please see each individual AKCP sensor product manual for more information on how to setup the AKCP sensors.

E) SNMP OID's for the CCU

sensorDoorIndex

.1.3.6.1.4.1.3854.2.3.27.1.1

sensorDoorDescription

.1.3.6.1.4.1.3854.2.3.27.1.2

sensorDoorValue

.1.3.6.1.4.1.3854.2.3.27.1.4

sensorDoorStatus

.1.3.6.1.4.1.3854.2.3.27.1.6

sensorDoorUnlockPeriod

.1.3.6.1.4.1.3854.2.3.27.1.62

sensorDoorOpenPeriod

.1.3.6.1.4.1.3854.2.3.27.1.63

sensorDoorCmd

.1.3.6.1.4.1.3854.2.3.27.1.64

6. CCU FAQ

1. What are the dimensions of the CCU?

Dimensions : Length 13.20 cm x Width 5.38 cm x Height: 3.40 cm

Weight (Approx) : 120 grams without cable

2. Will the CCU work as a stand-alone unit or do I need the DCU or securityProbe unit for it to connect to?

The Cabinet Control Unit is not a standalone cabinet controller. This means that it DOES require the Door Control Unit or the securityProbe to operate. A Cabinet Control Unit is capable of controlling the access to a server cabinet in computer room.

There is only one option available on the CCU. Controlling a single cabinet lock using the RFID card reader.

3. Can I monitor the Cabinet Control Unit with AKCess Pro Server Software without a DCU?

The Cabinet Control Unit is NOT a standalone product and needs to either be connected to a DCU or a securityProbe base unit to function. The AKCess Pro Server is required to configure the CCU, the RFID reader, door lock and the Intelligent Sensors connected to it. However, once configured the Cabinet Control Unit will run independently without the need for a direct connection to the AKCess Pro Server.

- 4. If my requirements are to monitor 50+ Racks with the Cabinet Control Units. Is this right that I need ONLY 1 Door Control Unit for this? What happens if the power is cut? How many CCU's can I daisy chain off of 1 DCU?**

The Door Control Unit has x2 Front Panel RJ45 Expansion Ports. Each expansion cable has a run length of 300m. However, as Expansion Units are connected in Series, if one unit encounters a communication problem all 50+ units would be un-accessible. Note that unless there was a power outage the cabinet lock WOULD remain locked.

A best practice, we would suggest you divide the CCU's up over a sufficient number of DCU's to prevent widespread inaccessibility in the event that a problem occurs on a single unit.

The best practice for daisy-chaining CCU's to the DCU's is 25 per string. That means 50 CCU's in total per DCU. The reason for this is to reduce the risk of chain communication failures.

- 5. On every Cabinet Control Unit I can connect 2 sensors. The sensor I can control with the Door Control Unit without a securityProbe – is this correct? How do I configure the sensors on a DCU and CCU?**

The Sensors need to be configured from the AKCess Pro Server Application. There is no User Interface on the Door Control Unit to configure Sensors. However, we have included the ability to create sensor notifications stored locally to the Door Control Unit.

- 6. What kind of electrical locks could be used in the doors (control voltage etc.)**

We offer and highly recommend our ACDL01 or ACDL02 EM door locks which are powered by the DCU or CCU. These require 12VDC. You can use your own door locks but we would need the specifications and wiring diagrams for this integration.

- 7. What about the need for external power supply for DCU's, readers, cameras, locks?**

The DCU, the CCU and the cameras require an AC power adapter which is included. The readers, doors locks and switches are all powered by the DCU or CCU.

8. **We have our own Wiegand card readers and door strikes with the following specifications. Can we connect these to the CCU?**

The maximum current draw for the standard 26-bit Wiegand card reader we use is 150mA@12Vdc (50mA@12Vdc in standby mode)

The maximum current draw for the electric door strike we use is 320mA@12Vdc in the Fail Secure mode (240mA@12Vdc in the Fail Safe mode)

The power requirement for the DCU is 3A@12Vdc. the DCU supplies power to two readers and one lock but we will use only one reader on the DCU.

The power requirement for the CCU is 1A@12Vdc. the CCU supplies power to one reader and one lock.

Could you confirm that the power supply through the CCU/DCU is sufficient for the card reader (150mA@12Vdc) and the door electric strike (320mA@12Vdc in Fail Secure) and the CCU/DCU itself?

Yes, This is confirmed.

9. **Is the 1A@12vdc power supply included with the CCU standalone? Otherwise can we use any higher power supply like 1.5A for the CCU? How many mAmps are allocated to the Lock and how many mAmps are allocated to the Reader?**

You can only use the power supply we include with the CCU. If you use your own power supply this may damage the unit and also it will void the warranty.

For the specification of the CCU, we provide 500 mA for the Door Lock and 200 mA for the Access Reader. This supports your needs.

10. **The distance between the furthest controlled door AND our IT Room where the Door Control Unit (DCU) will be, is 200 feet maximum. So the maximum total length of the electrical circuit is 2*200 feet=400 feet maximum (121.92 meters)**

Please keep in mind that we want to install the DCU as well as other the CCU in the IT Room at the same place as the centralized UPS backup.

**We have installed 6-conductor 18 AWG cable for the card readers.
We have installed 2-conductor 16 AWG cable for the electric door strike.**

To convert these multi-conductor cables into RJ45 plugs we will use this kind of breakout board which accepts up to 16 AWG wire sizes:

<http://www.winfordeng.com/products/brk8p8c.php>

Your team has already sent the new wiring diagram for the card reader and the lock connections after we sent you the digrams from the reader and lock supplier.

These RJ45 convertor boards will be installed not far from the DCU and CCU with approx. 3 feet 24 AWG CAT6 patch cables (~1 meter)

According to the maximum total length of the electrical circuit (400 ft or 120 meters) and the fact that we will use 2 kinds of cables for the door lock (3 feet of 24 AWG CAT6 patch cable then 200 feet of 16 AWG 6-conductor) do you see any problem such as potential voltage drop that would prevent the entire system from working?

For the Card Readers, there is no problem. You use 18 AWG according to the Wiegand Standard. The communication distance is more than 100 Meters.

For the Door Lock, we estimate that if the load of 320mA is connected to a 16 AWG, at 122 Meters plus the 24 AWG 2 at meters the total voltage drop is only 4.73%. So this should be fine for the door locks.

Our engineer did want to highlight some key issues and instructions you should follow for the installation.

When using a strike type door lock. Please put the diode close to the door lock and make sure that it is connected to the correct polarity. This type of door lock generates a large amount of EMI.

11. My customer is concerned about EMI interference from your EM door locks might cause problems with the electronics in his cabinets. Will this be a problem and how do I explain in detail how this will not be?

You can explain to your customer that normally, the magnitude of EMI depends on the size of the load. A large load can cause large amounts of EMI. As you can compare our product that consumes only 300 mA @ 12V and other lock types that requires 600mA @ 12V. Then we can see that our lock consumes less current and that should be causing less EMI.

To focus on operating methods, the EM lock will be locked when the power is on and unlocked when the power is off. Then there is only 2 transition states. Compared with other locks that requires an internal motor/inductor to change the state of the lock latch. Let's review this, to lock, it requires power to change the position of the lock latch to the locked position and then power down.

Next is to unlock, it will require power to change the position of the lock latch to the unlocked position and then power down. So there are 4 transition states. EMI is generated when there is a change of current, our lock generates 2 times when other locks generates up to 4 times.

In final our cabinet lock will have lower EMI than the other lock types and they will consume less power as well.

This should convince your customer that the EMI from the lock should not have any bad effects on the equipment in the cabinets.

This concludes the CCU user manual.

Please contact support@akcp.com if you have any further technical questions or problems setting up your modem or your alerts.

Thanks for Choosing AKCess Pro!